

Features

- Only one external component other than sense resistor in HEMT drain
- Preset references for common HEMT operating currents
- Other operating points can be set with two external resistors
- Logic level on/off control allows HEMT shutdown
- Full military temperature range
- Temperature indicator
- Minimizes power dissipation
- Low operating current
- Tight clamping of HEMT gate voltage
- Available packaged (SOIC-14) or as dice (74 x 79 mils)

Description

The HBC-1 provides an integrated solution to the biasing of HEMT devices used in millimeter wave amplifiers. These devices require tight control of the gate voltage to prevent damage to the gate and to stabilize the RF parameters such as gain and power output. In MMICs, minimization of biasing components is critical to packaging density. The HBC-1 requires only one external component other than the current sense resistor in the HEMT drain lead.

Package Diagrams

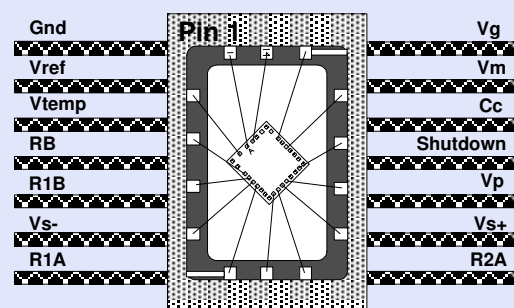

Ceramic SOIC-14

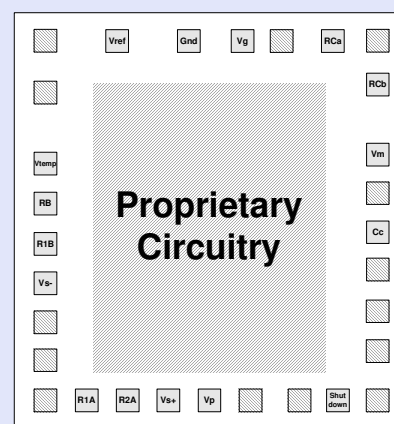

Dice
Size: 74 x 79 x 10 mils
Bond Pads: 4 mils square

SOIC-14 PINOUT

Pin#/Name	Function
1/Gnd	Ground.
2/Vref	Voltage Reference. Under correct operation $V_{ref} = +1.22V$ relative to V_m .
3/Vtemp	Temperature Sense Voltage. ^{6,7}
4/RB	Input Bias Current Programming Pin.
5/R1B	Connect to RB for Default Input Bias Current.
6/Vs-	Sense Minus.
7/R1A	Positive Input for 108mV Sense Voltage.
8/R2A	Positive Input for 82mV Sense Voltage.
9/Vs+	Sense Voltage – User Defined.
10/Vp	V Positive – Positive Voltage Input.
11/Shutdown	Shutdown ⁵ – Logic Level On/Off Control. Active Low.
12/Cc	(Phase) Compensation Capacitor. 10nF from Cc to V_m required for unconditional stability.
13/ V_m	V Minus – Negative Voltage Input.
14/ V_g	Gate Voltage – Output to HEMT Gate.

Specifications

Unless otherwise specified: $V_p=+4.5V$; $V_m=-5.0V$; $-55C$ to $+125C$; Typical at $+25C$

PARAMETER		Units	MIN	TYPICAL	MAX
Supply Voltage ¹	V_p	Volts	2.5	4.5	15
	V_m		-15	-5.0	-3.0
Gate Voltage Upper Clamp	V_g max	volts	-0.02	-0.01	0.00
Gate Voltage Lower Clamp	V_g min	volts	-1.05	-1.00	-0.91
Positive Supply Current	I_{Vp}	ma	0.4	0.55	0.7
Negative Supply Current ²	I_{Vm}	ma	1.5	2.0	2.6
Sense Voltage ($V_{s+} - V_{s-}$) (See Table 1)	$V_p = R1A$ $RB = R1B$	mv	99	108	122
	$V_p = R2A$ $RB = R1B$	mv	75	82	96
Short Circuit Output Current (output grounded)	I_{sc}	ma		9.5	13
Common Mode Input Voltage		volts	0		V_p
Input Bias Current	$V_{s+}, R1A,$ $R2A$	μa		109	
	V_{s-}			.010	
Open-Loop Gain (V_{s-} to V_g , 100 Hz)		dB		54	
Gain-Bandwidth Product ³		MHz		1	
Phase Margin ⁴		deg		50	
CMRR (10 kHz)		dB		32	
PSRR (10 kHz)	V_p	dB		59	
	V_m			59	
Shutdown Voltage ⁵	Threshold	volts		1.5	
	Hysteresis	MV		500	
Shutdown Response Time (on or off)		μs		20	
Temperature Sensor ^{6,7}	Slope	$mV/^{\circ}C$		-2.84	
	Offset	$mV @ 25^{\circ}C$	-850	-700 (See Notes 6&7)	-575

Notes:

¹Positive supply voltage to the HEMT must not be present unless the HBC-1 negative supply voltage is at or more negative than three volts. Failure to observe this precaution will prevent the HBC-1 from being able to maintain a negative gate voltage to the HEMT, and damage to or destruction of the HEMT may result. The HBC-1 itself is fully functional at zero positive supply voltage.

²Values given are for normal operation. For output shorted to ground, max is 5 ma.

³Capacitance of 0 to 200 pF at gate voltage output Vg.

⁴The HBC-1 is noninverting from Vs- to Vg. Phase margin is 180 degrees minus input to output phase lag at unity gain crossover.

⁵The shutdown pin may be left floating if unused. It is internally pulled up. Allowable voltage input is -0.3 V to Vp + 0.3 V. Max input current is 1 mA.

⁶The temperature sense is not intended as a precision device but to allow assessment of temperature rise of the part as installed. The slope is quite linear and predictable, but the offset should be characterized for each device at a known temperature. The sensor voltage is measured with respect to ground. The offset may range from -0.575 to -.850 Volts device to device. The slope of -2.84 mV/°C is typically linear within +3.3 degrees C from +25 to -55 degrees C and -3.2 degrees C from +25 to +125 degrees C. The slope of the Temperature Versus Voltage does become slightly steeper at -55 degrees C and slightly less steep at +125 degrees C. Typically when one thinks they are at -55 degrees C from assuming perfect linearity, they are usually actually at -51.7 degrees C, and when one thinks they are at 125 degrees C, they are actually at 128.2 degrees C. By applying an intentional 1.65 degrees offset error at +25 degrees C (that is, add a +1.65 degree C offset to +25 C in the formula), the linearity can be improved to +/-1.65 degrees C.

⁷Temperature Sense Voltage is produced by sinking a temperature-varying current through a 7.5kOhm +/-20% resistor to ground. Loading the temperature sense pin can vary the temperature sense voltage. The typical room-temperature current used to establish the temperature voltage is, therefore, 700mV/7.5kOhm ~ 10uA. The load should sink considerably less than 10uA.

Specifications subject to change without notice.

Absolute Maximum Limits

Supply Voltages.....	$-0.3V \leq Vp \leq +20V$ $-20V \leq Vm \leq +0.3V$ $-0.3V \leq (Vp - Vm) \leq +20V$
Input Voltage(Vs+ or Vs-).....	$Vm - 0.3V \leq Vs \leq Vp + 0.3V$
Differential Input Voltage.....	$ Vs+ - Vs- \leq 7V$
Voltage Applied to R1A or R2A.....	$Vm - 0.3V \leq VA \leq Vp + 0.3V, VA \leq Vs- + 7V$
Voltage Applied to RB.....	$Vm - 0.3V \leq VB \leq Vs- + 6V$
Output Short Circuit Duration.....	Unlimited to ground

PIVC, L.L.C.

A Subsidiary of Phase IV Systems, Inc.

Email: info@pivc.com Web: www.pivc.com

3405 Triana Boulevard Huntsville, AL 35805-4695

Phone: (256) 705-2219 Fax: (256) 535-2110 Toll Free: (800) 748-2552

Typical Application

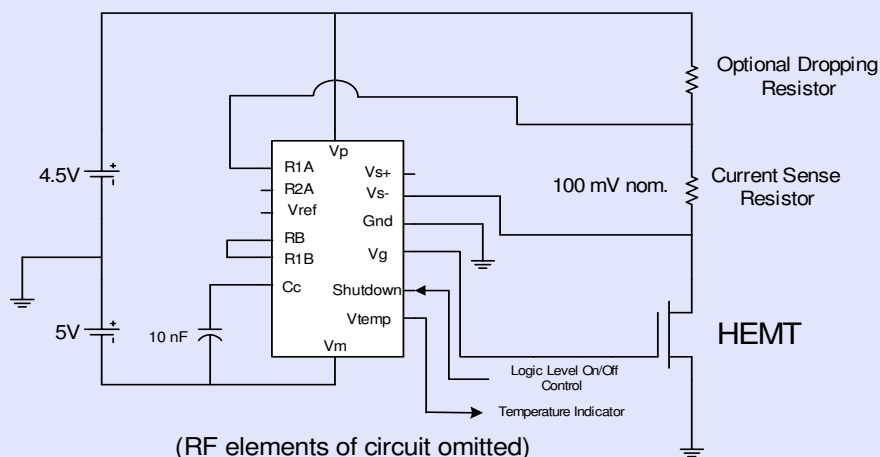

Table 1 - Typical Operating Configuration

HEMT Operating Current	Sense Resistor	Sense Terminal
114 ma	0.953 ohm	R1A
275 ma	0.300 ohm	R2A
413 ma	0.200 ohm	R2A
826 ma	2 - 0.200 ohm in parallel	R2A

PIVC, L.L.C.

A Subsidiary of Phase IV Systems, Inc.

Email: info@pivc.com Web: www.pivc.com

3405 Triana Boulevard Huntsville, AL 35805-4695

Phone: (256) 705-2219 Fax: (256) 535-2110 Toll Free: (800) 748-2552

Typical Layout Using Dice

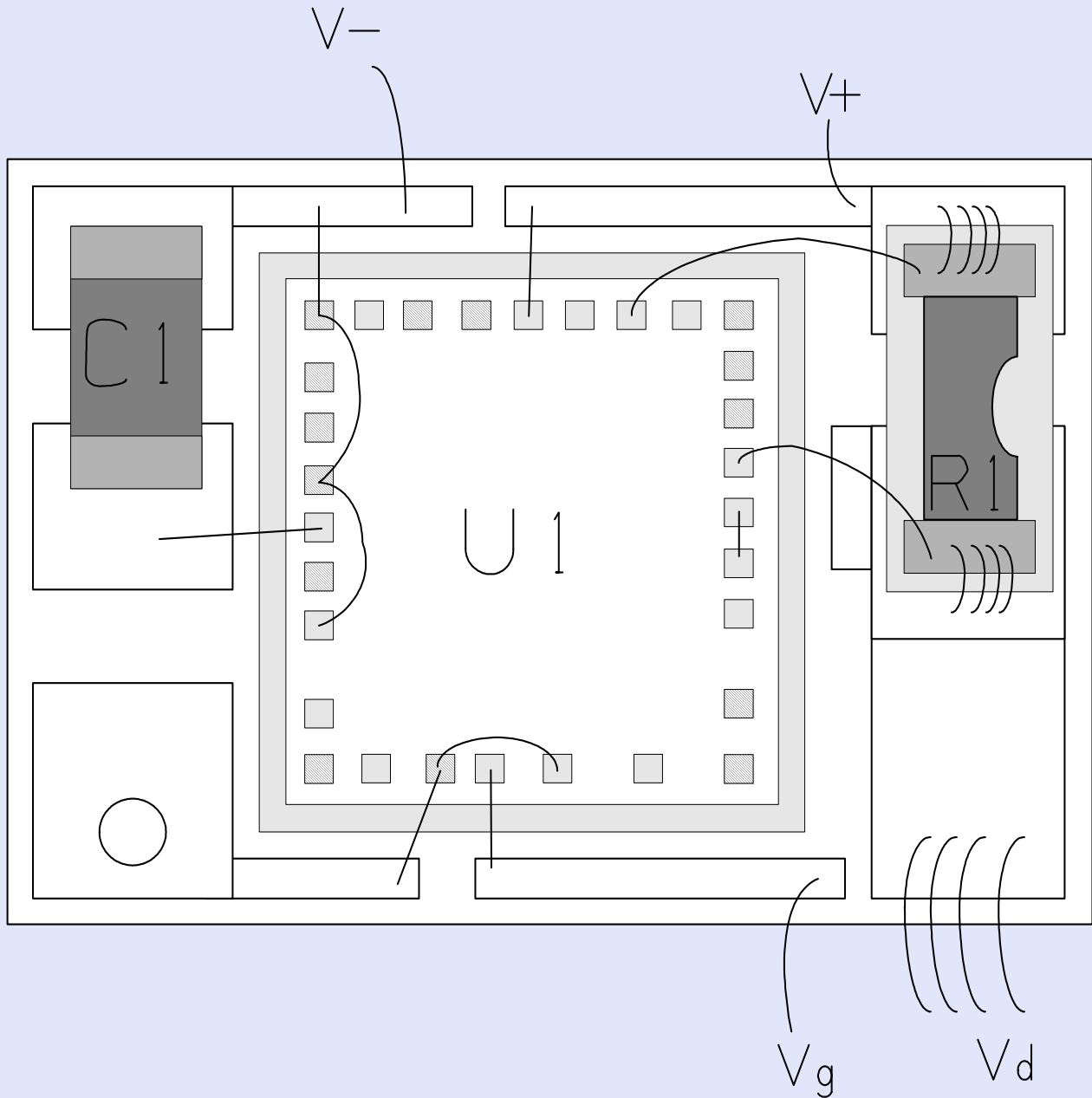

Notes:

¹Dashed wire bonds indicate options.

²Substrate is connected to V_m .

PIVC, L.L.C.

A Subsidiary of Phase IV Systems, Inc.

Email: info@pivc.com Web: www.pivc.com

3405 Triana Boulevard Huntsville, AL 35805-4695

Phone: (256) 705-2219 Fax: (256) 535-2110 Toll Free: (800) 748-2552

Outline Dimensions

Reference

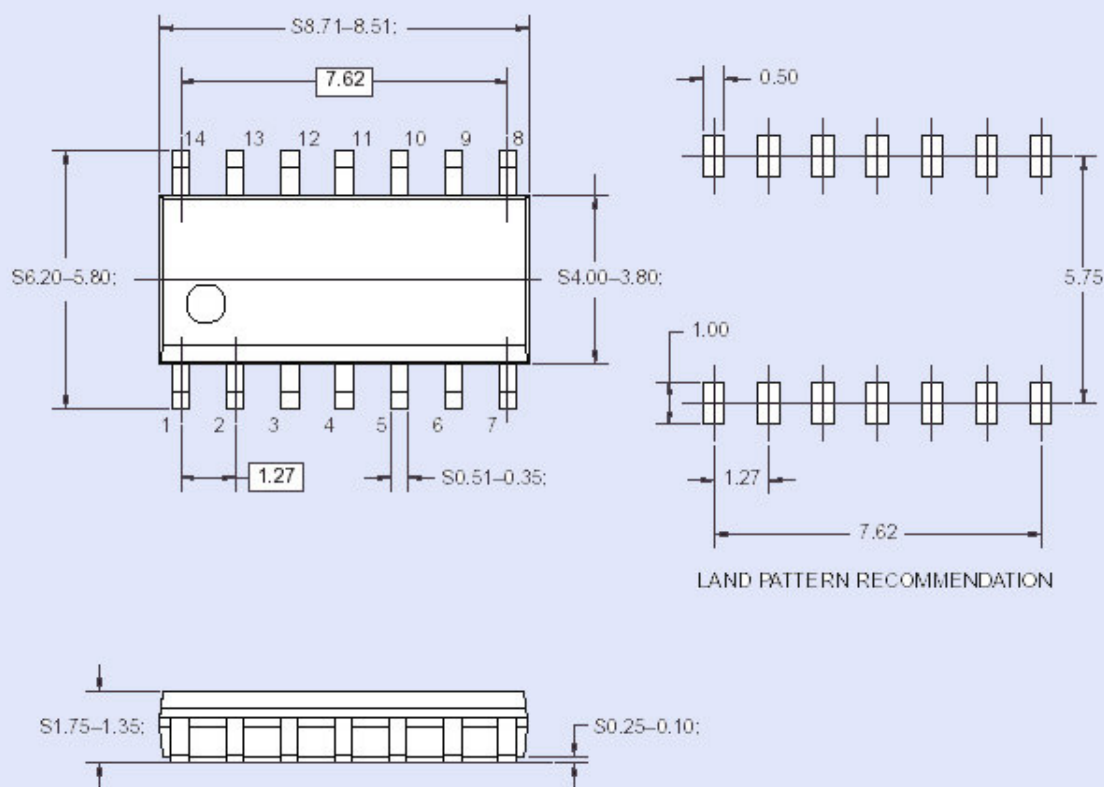

Notes:

- ¹All dimensions are in millimeters.
- ²Contact PIVC, L.L.C. for actual dimensions.
- ³Subject to change without notice.

Only²

PIVC, L.L.C.

A Subsidiary of Phase IV Systems, Inc.

Email: info@pivc.com Web: www.pivc.com

3405 Triana Boulevard Huntsville, AL 35805-4695

Phone: (256) 705-2219 Fax: (256) 535-2110 Toll Free: (800) 748-2552