

Features

- Provides an interface between the host range communications link (HRCL) and the MRGS allowing the range users to use their existing Full-rate Production (FRP) MRGSs with the new Message Processor II (MPIO) based ARDS Data Link Ground System with minimal re-configuration.
- Emulates original MP interface for the FRP MRGSs and provides an industry standard RS422/SDLC synchronous interface on the MPIO/HRCL side.
- Distributed timing and frame synchronization. All MRGS one-second frame boundaries are synchronized to GPS 1PPS to eliminate the HRCL from the critical timing path.
- Provides increased network stability.
- The MMIU in conjunction with the MPIO allows ranges to install MRGSs several hundred miles away from the MPIO.
- An Ethernet Bridge may be used at the remote site to provide a 10BASET Ethernet connection to the HRCL.

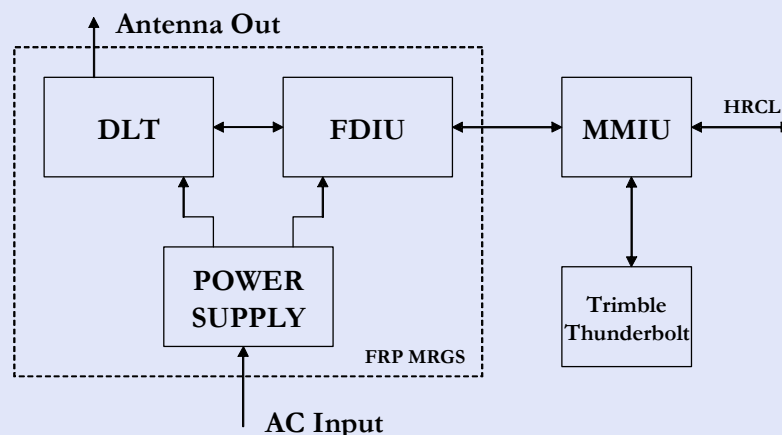

PIVC, L.L.C.

A Subsidiary of Phase IV Systems, Inc.

Email: info@pivc.com Web: www.pivc.com

3405 Triana Boulevard Huntsville, AL 35805-4695

Phone: (256) 705-2219 Fax: (256) 535-2110 Toll Free: (800) 748-2552

Specifications

Parameter	Value
Input Voltage	7-30 VDC
Input Power	~12W
1PPS	Single Ended or Differential
Operating Temp	-40 to + 85 DegC
Storage Temp	-40 to +85 DegC
Humidity	5-95% non-condensing
System Architecture	PC/104
Dimensions	7.5"L x 6"W x 6"H

Also Available:

MRGS Upgrade Kit(P/N: MRGS-KIT-01)

Kit Includes:

- MMIU
- 24V AC/DC Power Supply (120V AC Input)
- Trimble Thunderbolt GPS Receiver with Holdover
- WebRanger II Ethernet Bridge
- Interconnect Cables

This kit includes everything needed to convert your existing FRP MRGS to an MPII compatible MRGS. All that is required is an interface cable from your communications equipment to the Ethernet Bridge if using RS422/HDLC over the communications link. Ethernet cables are not provided.

PIVC, L.L.C.

A Subsidiary of Phase IV Systems, Inc.

Email: info@pivc.com Web: www.pivc.com

3405 Triana Boulevard Huntsville, AL 35805-4695

Phone: (256) 705-2219 Fax: (256) 535-2110 Toll Free: (800) 748-2552